

ROBOTICS

Product manual

OmniCore A400XT



Trace back information:
Workspace 24D version a3
Checked in 2024-12-05
Skribenta version 5.6.018

Product manual
OmniCore A400XT

OmniCore

Document ID: 3HAC090255-001

Revision: B

The information in this manual is subject to change without notice and should not be construed as a commitment by ABB. ABB assumes no responsibility for any errors that may appear in this manual.

Except as may be expressly stated anywhere in this manual, nothing herein shall be construed as any kind of guarantee or warranty by ABB for losses, damage to persons or property, fitness for a specific purpose or the like.

In no event shall ABB be liable for incidental or consequential damages arising from use of this manual and products described herein.

This manual and parts thereof must not be reproduced or copied without ABB's written permission.

Keep for future reference.

Additional copies of this manual may be obtained from ABB.

Original instructions.

© Copyright 2024 ABB. All rights reserved.
Specifications subject to change without notice.

Table of contents

Overview of this manual	7
Product documentation	9
1 Safety	11
1.1 Limitation of liability	11
1.2 Safety during installation and commissioning	12
2 Controller description	13
2.1 OmniCore A400XT	13
2.2 Technical data for OmniCore A400XT	14
3 Installation	17
3.1 Introduction to installation	17
3.2 Installation activities	18
3.3 Transporting and handling	19
3.3.1 Lifting the controller cabinet	19
3.3.2 Unpacking	20
3.3.3 Storing	21
3.4 On-site installation	22
3.4.1 Securing and stacking the cabinet	22
3.4.2 Connecting protective earth	23
4 Maintenance	25
4.1 Maintenance schedule	25
4.2 Cleaning of the controller cabinet	26
5 Repair	27
5.1 Replacement of controller parts	27
5.1.1 Opening the cabinet	27
5.1.2 Replacing the door lock insert	28
5.1.3 Replacing the cabinet wheels	30
5.1.4 Replacing the cable grommet assembly	33
5.1.5 Replacing the process cable gland	35
6 Decommissioning	37
6.1 Introduction to decommissioning	37
6.2 Environmental information	38
7 Reference information	39
7.1 Introduction	39
7.2 Unit conversion	40
7.3 Standard toolkit for controller	41
7.4 Screw joints	42
7.5 Weight specifications	43
7.6 Lifting accessories and lifting instructions	44
8 Spare parts	45
8.1 Controller parts	46
8.1.1 Cabinet parts	47
8.1.2 Miscellaneous parts	49
Index	51

This page is intentionally left blank

Overview of this manual

About this manual

This manual contains instructions for:

- mechanical and electrical installation of the controller
- maintenance of the controller
- mechanical and electrical repair of the controller

Usage

This manual should be used during:

- installation and commissioning, from lifting the product to its work site and securing it to the foundation, to making it ready for operation
- maintenance work
- repair work
- decommissioning work



Note

It is the responsibility of the integrator to conduct a risk assessment of the final application.

It is the responsibility of the integrator to provide safety and user guides for the robot system.

Who should read this manual?

This manual is intended for:

- installation personnel
- maintenance personnel
- repair personnel.

Prerequisites

A maintenance/repair/installation craftsman working with an ABB robot must:

- be trained by ABB and have the required knowledge of mechanical and electrical installation/repair/maintenance work.
- be trained to respond to emergencies or abnormal situations.

Product manual scope

The manual covers all variants and designs of the OmniCore A400XT. Some variants and designs may have been removed from the business offer and are no longer available for purchase.

Continues on next page

Overview of this manual

Continued

References



Tip

All documents can be found via myABB Business Portal, www.abb.com/myABB.

Document name	Document ID
<i>Product specification - OmniCore A line</i>	3HAC091291-001
<i>Safety manual for robot - Manipulator and IRC5 or OmniCore controller</i>	3HAC031045-001

Revisions

Revision	Description
A	First edition.
B	Published in release 24D. The following updates are made in this revision: <ul style="list-style-type: none">• New option added: <i>3011-1 Wheels</i>.• New section about safety labels: Safety symbols on cabinet labels on page 12.

Product documentation

Categories for user documentation from ABB Robotics

The user documentation from ABB Robotics is divided into a number of categories. This listing is based on the type of information in the documents, regardless of whether the products are standard or optional.



Tip

All documents can be found via myABB Business Portal, www.abb.com/myABB.

Product manuals

Manipulators, controllers, DressPack, and most other hardware is delivered with a **Product manual** that generally contains:

- Safety information.
- Installation and commissioning (descriptions of mechanical installation or electrical connections).
- Maintenance (descriptions of all required preventive maintenance procedures including intervals and expected life time of parts).
- Repair (descriptions of all recommended repair procedures including spare parts).
- Calibration.
- Troubleshooting.
- Decommissioning.
- Reference information (safety standards, unit conversions, screw joints, lists of tools).
- Spare parts list with corresponding figures (or references to separate spare parts lists).
- References to circuit diagrams.

Technical reference manuals

The technical reference manuals describe reference information for robotics products, for example lubrication, the RAPID language, and system parameters.

Application manuals

Specific applications (for example software or hardware options) are described in **Application manuals**. An application manual can describe one or several applications.

An application manual generally contains information about:

- The purpose of the application (what it does and when it is useful).
- What is included (for example cables, I/O boards, RAPID instructions, system parameters, software).
- How to install included or required hardware.
- How to use the application.

Continues on next page

- Examples of how to use the application.

Operating manuals

The operating manuals describe hands-on handling of the products. The manuals are aimed at those having first-hand operational contact with the product, that is production cell operators, programmers, and troubleshooters.

1 Safety

1.1 Limitation of liability

Limitation of liability

Any information given in this manual regarding safety must not be construed as a warranty by ABB that the industrial robot will not cause injury or damage even if all safety instructions are complied with.

The information does not cover how to design, install and operate a robot system, nor does it cover all peripheral equipment that can influence the safety of the robot system.

In particular, liability cannot be accepted if injury or damage has been caused for any of the following reasons:

- Use of the robot in other ways than intended.
- Incorrect operation or maintenance.
- Operation of the robot when the safety devices are defective, not in their intended location or in any other way not working.
- When instructions for operation and maintenance are not followed as intended.
- Non-authorized design modifications of the robot.
- Repairs on the robot and its spare parts carried out by in-experienced or non-qualified personnel.
- Foreign objects.
- Force majeure.

Spare parts and equipment

ABB supplies original spare parts and equipment which have been tested and approved for their intended use. The installation and/or use of non-original spare parts and equipment can negatively affect the safety, function, performance, and structural properties of the robot. ABB is not liable for damages caused by the use of non-original spare parts and equipment.

1 Safety

1.2 Safety during installation and commissioning

1.2 Safety during installation and commissioning

National or regional regulations

The integrator of the robot system is responsible for the safety of the robot system.

The integrator is responsible that the robot system is designed and installed in accordance with the safety requirements set forth in the applicable national and regional standards and regulations.

The integrator of the robot system is required to perform a risk assessment.

Safety symbols on cabinet labels

The cabinet is marked with labels containing safety symbols and important information about the product. The purpose of the labels is to ensure personal safety for all personnel handling the robot, for example during installation, service, or operation.



The safety symbols are language independent, they only use graphics. The information labels contain information in text. See [Symbols and information on labels on page 12](#).



Note

The safety and information labels on the product must be observed.

Symbols and information on labels

Label	Description
 xx1400001152	Read the user manual before use.
 xx2400001821	Tip over hazard when cabinet is empty and not secured to the ground.

Related information

See the product manual for the connected robot controller.

2 Controller description

2.1 OmniCore A400XT

About OmniCore A400XT

The OmniCore A400XT is one of the OmniCore A line cabinets. OmniCore A line is a series of cabinets for integration of, for example, application equipment with the same high degree of flexibility as the OmniCore controllers.

2 Controller description

2.2 Technical data for OmniCore A400XT

2.2 Technical data for OmniCore A400XT

Overview

OmniCore A400XT is intended to be used in industrial environment.

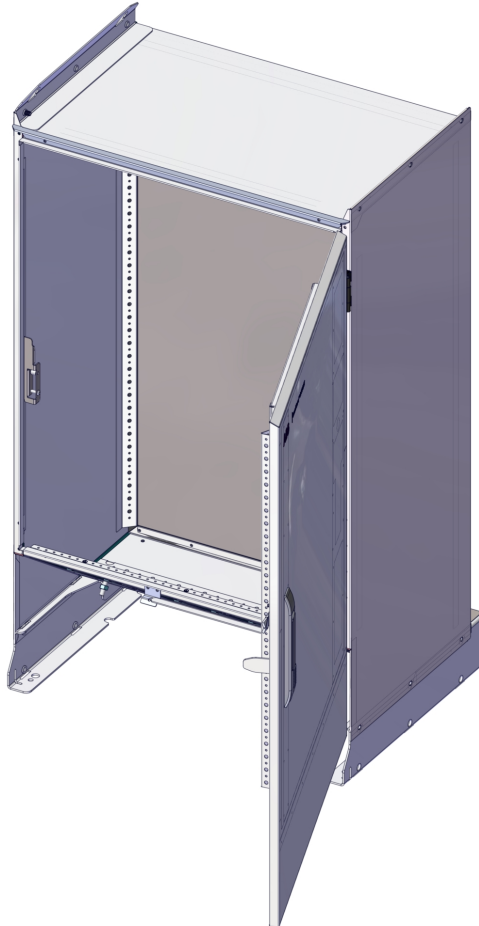

xx2400001196

Dimensions

Parameter	Value
Width	650 mm
Depth	466 mm
Height	1,138 mm

Weight

Controller	Weight
OmniCore A400XT	38 kg



Note

The weight does not include any mounting kits fitted on the controller.

Continues on next page

Transportation and storage conditions

Parameter	Value
Minimum ambient temperature	-40 °C (-40 °F)
Maximum ambient temperature	+55 °C (+131 °F)
Maximum ambient temperature (less than 24 hrs)	+70 °C (+158 °F)

After storage, the operating conditions inside the controller must be met for at least 6 hours.

The robot controller shall be stored according to its IP classification.

Operating conditions

The table shows the allowed operating conditions for the controller.

Parameter	Value
Minimum ambient temperature	+5 °C (+41 °F)
Maximum ambient temperature	+45 °C (+113 °F)
Maximum ambient altitude	2,000 m

Protection classes

	Protection class
Controller cabinet	IP54

The cabinet must be closed and sealed when no internal access is required.

If the cabinet is not properly closed and sealed (door and cable grommets), it does not comply with the protection class (IP54) and may affect the following:

- Units inside the cabinet are exposed to dust or moisture. Especially important in cases with high heat and humidity, or much pollution.



Note

To comply with IP54, all openings to the controller cabinet must be sealed. This includes unconnected connectors which must be fitted with covers.

This page is intentionally left blank

3 Installation

3.1 Introduction to installation

General

This chapter contains assembly instructions and information for installing the OmniCore A400XT at the working site.

See also the product manual for the robot controller of the same size as the OmniCore A400XT.

The installation must be done by qualified installation personnel in accordance with the safety requirements set forth in the applicable national and regional standards and regulations.

The technical data is detailed in section [Technical data for OmniCore A400XT on page 14](#).

Safety information

Before any installation work is commenced, all safety information must be observed. There are general safety aspects that must be read through, as well as more specific safety information that describes the danger and safety risks when performing the procedures. Read the chapter [Safety on page 11](#) before performing any installation work.



CAUTION

The cabinet might tip over when opened if it is empty and not secured to the ground. It is the responsibility of the integrator to analyze the tipping risk and determine possible measures.

3 Installation

3.2 Installation activities

3.2 Installation activities

Main steps for installing the cabinet

Use the following main steps to install the cabinet.

	Action	Described in
1	Unpack the cabinet.	Unpacking the controller on page 20.
2	Place the cabinet in position and bolt it to the ground.	On-site installation on page 22.
3	If needed, connect the cabinet to protective earth.	Connecting protective earth on page 23
4	Install the required DIN rails and terminal rails from the installation kit.	The number of rails depend on the size of the controller.
5	Install options and additional process equipment.	

3.3 Transporting and handling

3.3.1 Lifting the controller cabinet

Lifting device

The following figure shows the maximum angle between the lifting straps when lifting the controller. The weight of the controller module is detailed in section [Weight on page 14](#).

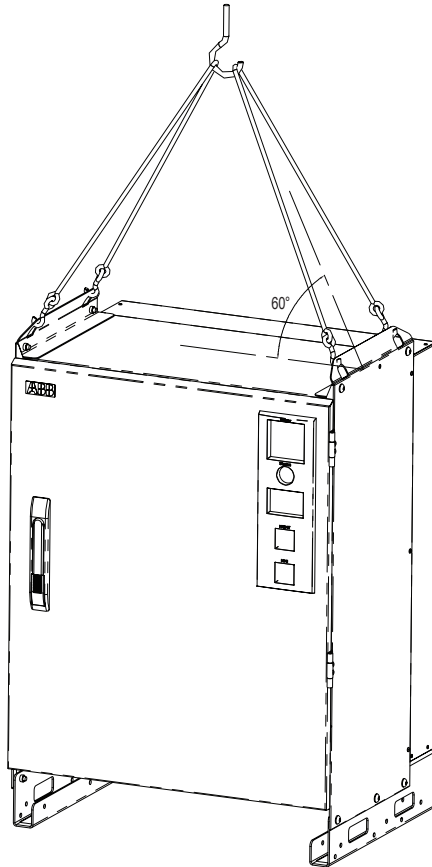

xx210000343

3 Installation

3.3.2 Unpacking

3.3.2 Unpacking

Unpacking the controller

	Action
1	Make a visual inspection of the packaging and make sure that nothing is damaged.
2	Remove the packaging.
3	Check for any visible transport damage.  Note Stop unpacking and contact ABB if transport damage is found.
4	Clean the unit with a lint-free cloth, if necessary.
5	Make sure that the lifting accessory used (if applicable) is suitable to handle the weight of the controller.
6	If the controller is not installed directly, it must be stored as described in Transportation and storage conditions on page 15 .
7	Make sure that the expected operating environment of the controller conforms to the specifications as described in Operating conditions on page 15 .
8	The controller can be taken to its installation site as described in section On-site installation on page 22 .

3.3.3 Storing

Storing the controller

For storing, see [Transportation and storage conditions on page 15](#).

3 Installation

3.4.1 Securing and stacking the cabinet

3.4 On-site installation

3.4.1 Securing and stacking the cabinet

Securing the controller

The controller can be secured to the ground. The figure below shows the bolt pattern for the OmniCore A400XT controller. The diameter of the four bolt holes are 14 mm.

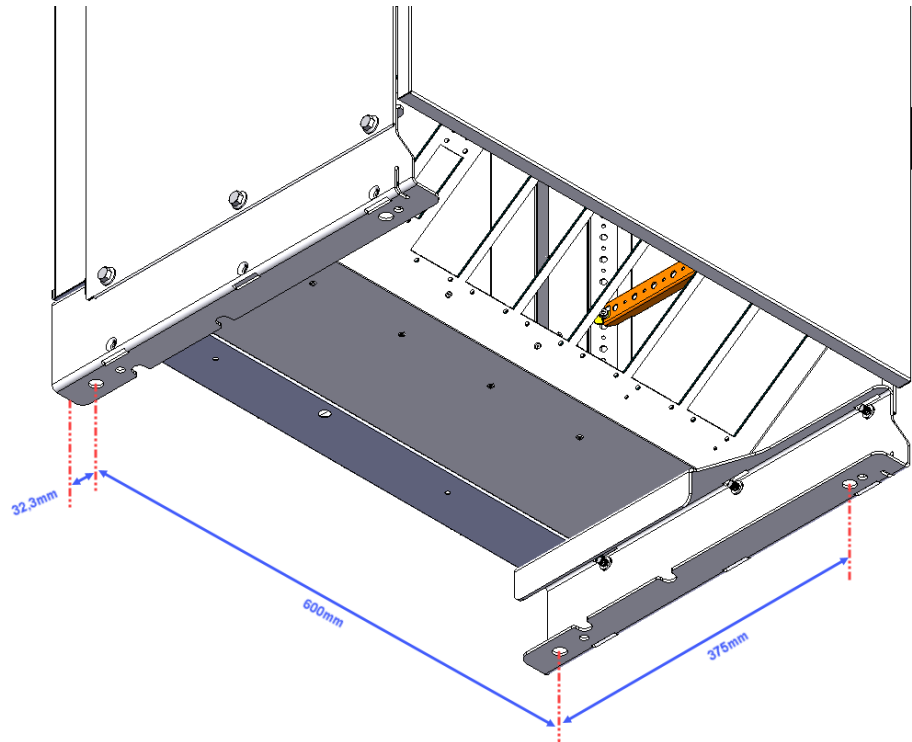

xx2200001823

Stacking the controller

The OmniCore A400XT controller is designed so that a maximum of two controllers can be stacked. The controllers must be safely fixed to each other, and it must be assured that the opened door on the upper controller does not cause imbalance.



CAUTION

The stacked cabinets must be secured to the floor accordingly.



Note

For lifting restrictions regarding stacked cabinets, see [Lifting the controller cabinet on page 19](#).

3.4.2 Connecting protective earth

Connection of protective earth

Use PE0 on the front panel to connect the cabinet to protective earth:

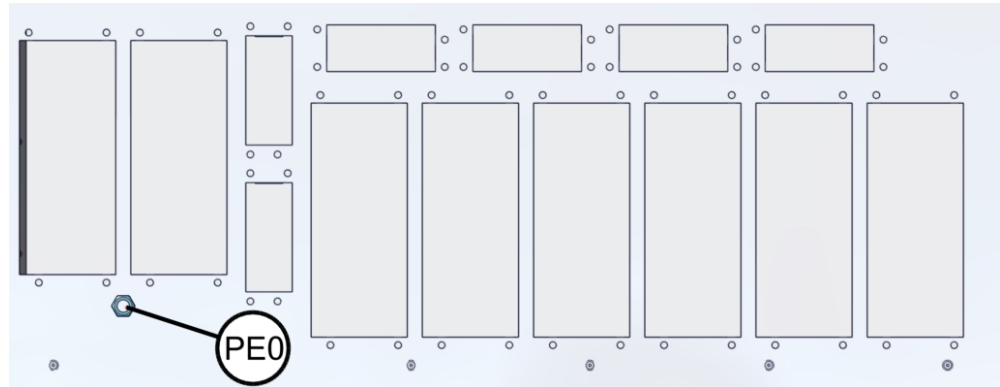

xx2400001198



Note

All connections between the cabinet and protective earth must comply with the local electrical requirements.

This page is intentionally left blank

4 Maintenance

4.1 Maintenance schedule

General

The cabinet must be maintained at regular intervals to ensure its function. The activities and intervals are described in this section.

Activities and intervals

Equipment	Maintenance activity	Interval	Detailed in section:
Control cabinet	Cleaning		<i>Cleaning of the controller cabinet on page 26</i>

4 Maintenance

4.2 Cleaning of the controller cabinet

4.2 Cleaning of the controller cabinet

Required equipment

Equipment, etc.	Note
Vacuum cleaner	ESD protected

Cleaning considerations

This section specifies some special considerations when cleaning the controller.

- Always use ESD protection.
- Always use cleaning equipment as specified above. Any other cleaning equipment may shorten the life of paint work, rust inhibitors, signs, or labels.
- Always make sure that all protective covers are fitted to the controller before cleaning.
- Never remove any covers or other protective devices when cleaning the outside of the controller.
- Never use compressed air or spray with a high pressure cleaner.
- Never leave the door open when cleaning the exterior.

5 Repair

5.1 Replacement of controller parts

5.1.1 Opening the cabinet

Opening the door

	Action	Info/illustration
1	Insert the key to the door and turn it anti-clockwise.	
2	Pull out the handle and turn it anti-clockwise.	
3	Pull out the door with the handle.	
4	 Tip Use the door stop to lock the door position before maintenance is started.	

Closing the door

	Action	Info/illustration
1	If door stop has been used during maintenance, place the door stop in its original position.	
2	Push the door back.	
3	Turn the handle clockwise and push it back into the lock.	
4	Turn the key back and take it out.	

5 Repair

5.1.2 Replacing the door lock insert

5.1.2 Replacing the door lock insert

Location

The illustration shows the location of the door lock.

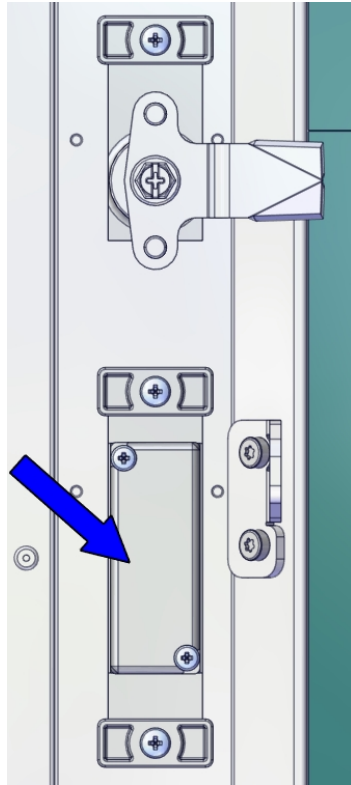

xx2400000104

Required spare parts



Note

The spare part numbers that are listed in the table can be out of date. See the latest spare parts of the OmniCore A400XT via myABB Business Portal, www.abb.com/myABB.

Removing the lock insert

	Action	Note/Illustration
1	Open the door.	Opening the door on page 27.

Continues on next page

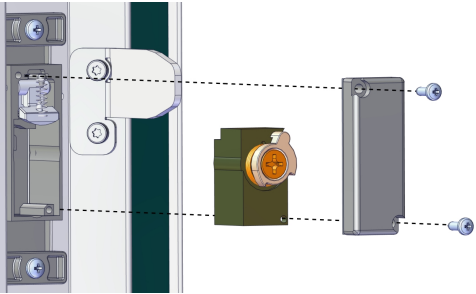
	Action	Note/Illustration
2	Remove the two screws and lift off the cover.	 <p data-bbox="959 618 1062 640">xx240000101</p>
3	Release the lever and remove the lock insert.	

Refitting the lock insert

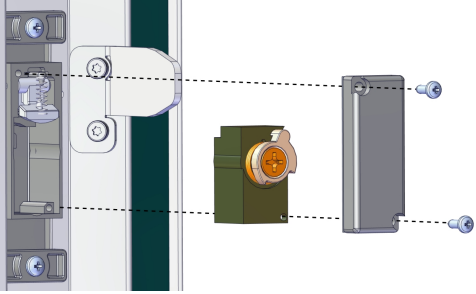
	Action	Note/Illustration
1	Put the lock insert in place.	
2	Refit the cover and tighten the two screws.	 <p data-bbox="959 1216 1062 1238">xx240000101</p> <p data-bbox="959 1249 1225 1272">Tightening torque: 2 Nm</p>
3	Close the door.	Closing the door on page 27.

5 Repair

5.1.3 Replacing the cabinet wheels

5.1.3 Replacing the cabinet wheels

Location

The illustration shows the location of the cabinet wheels.



xx2400002139

Required spare parts



Note

The spare part numbers that are listed in the table can be out of date. See the latest spare parts of the OmniCore A400XT via myABB Business Portal, www.abb.com/myABB.

Removing the wheels

Removing the rear wheel

	Action	Note/Illustration
1	Lift the cabinet with a forklift.	

Continues on next page

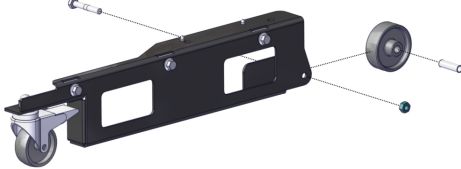
	Action	Note/Illustration
2	Remove the screw that holds the rear wheel and the wheel axle.	 <p>xx2400000331</p>
3	Remove the wheel axle and the wheel.	

Removing the front wheel

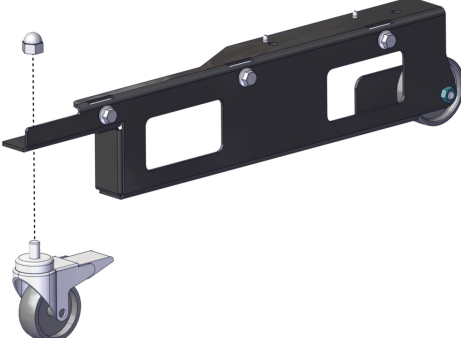
	Action	Note/Illustration
1	Lift the cabinet with a forklift.	
2	Loosen the nut that holds the head cap screw. Use a ball end allen key to hold the screw from underneath.	 <p>xx2400000332</p>
3	Remove the screw and the front wheel assembly.	

Refitting the wheels

Refitting the rear wheel

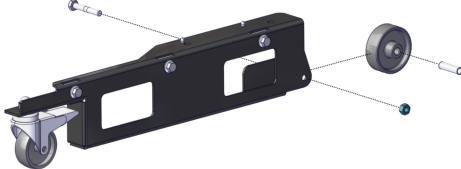
	Action	Note/Illustration
1	Place the wheel in the wheel beam.	
2	Insert the wheel axle and the screw through the wheel. Secure the screw.	 <p>xx2400000331</p> <p>Tightening torque: 24 Nm</p>

Refitting the front wheel

	Action	Note/Illustration
1	Place the wheel in the wheel beam.	

Continues on next page

5 Repair

5.1.3 Replacing the cabinet wheels

Continued

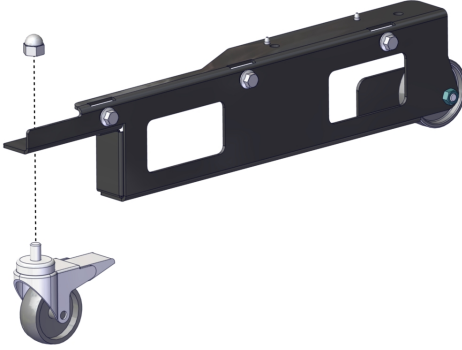
	Action	Note/Illustration
2	Insert the head cap screw through the wheel. Secure with the nut.	 <p data-bbox="925 694 1029 712">xx240000332</p> <p data-bbox="925 728 1204 750">Tightening torque: 30 Nm</p>

5.1.4 Replacing the cable grommet assembly

Location

The cable grommet assembly is located in the fixed installation panel.



Note

The end user needs to install proper grommets according to the diameter of the cables which need to go through the grommet.

Incorrect use of grommets will affect ingress protection, EMI/EMC and temperature.

It is recommended to use icotek KT grommet.

Required spare parts



Note

The spare part numbers that are listed in the table can be out of date. See the latest spare parts of the OmniCore A400XT via myABB Business Portal, www.abb.com/myABB.

Spare part	Article number	Note
Cable grommet asm	3HAC066396-001	
Blind plate	3HAC069954-001	

Required tools and equipment

Equipment	Article number	Note
Standard toolkit	-	Content is defined in section Standard toolkit for controller on page 41 .
ESD protective wrist band	-	

Removing the cable grommet assembly

	Action	Note/Illustration
1	Open the door.	Opening the door on page 27 .

Continues on next page

5 Repair

5.1.4 Replacing the cable grommet assembly

Continued

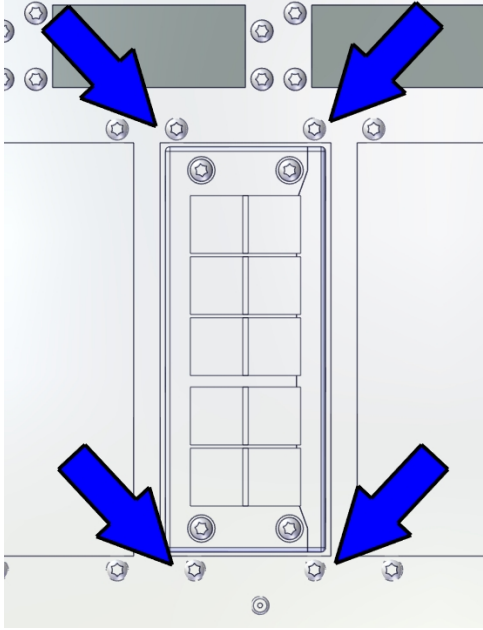
Action	Note/Illustration
<p>2 Remove the attachment screws on the fixed installation panel.</p>	 <p>xx2400001199</p>
<p>3 Push the cable grommet assembly into the cabinet.</p>	
<p>4 Remove the cable grommet assembly.</p>	

Refitting the cable grommet assembly

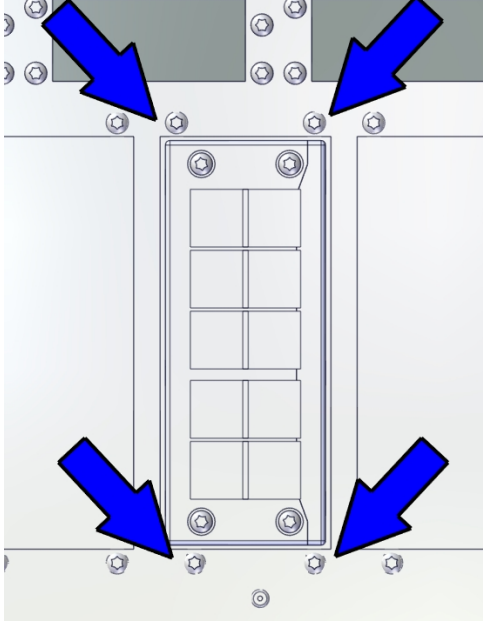
Action	Note/Illustration
<p>1 Place the cable grommet assembly in the fixed installation panel and secure it with the screws.</p>	<p>Screws: Torx pan head screw M4x8 (4 pcs)</p>  <p>xx2400001199</p>
<p>2 Close the door.</p>	<p><i>Closing the door on page 27.</i></p>

5.1.5 Replacing the process cable gland

Location

The illustration shows the location of the process cable gland on the controller.

Required spare parts



Note

The spare part numbers that are listed in the table can be out of date. See the latest spare parts of the OmniCore A400XT via myABB Business Portal, www.abb.com/myABB.

Spare part	Article number	Note
Cable gland process interface	3HAC079449-001	

Required tools and equipment

Equipment	Article number	Note
Standard toolkit	-	Content is defined in section Standard toolkit for controller on page 41 .
ESD protective wrist band	-	

Removing the process cable gland

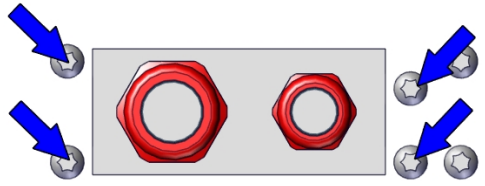
	Action	Note/Illustration
1	Open the door.	Opening the door on page 27 .
2	Remove the attachment screws on the fixed installation panel.	 xx2400001203
3	Push the process cable gland into the cabinet.	
4	Remove the process cable gland.	

Continues on next page

5 Repair

5.1.5 Replacing the process cable gland

Continued

Refitting the process cable gland

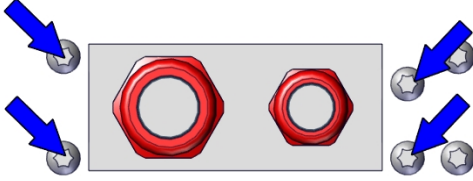
	Action	Note/Illustration
1	Place the process cable gland into the fixed installation panel and secure it with the screws.	<p>Screws: Torx pan head screw M4x8 (4 pcs)</p>  <p>xx2400001203</p>
2	Close the door.	Closing the door on page 27.

6 Decommissioning

6.1 Introduction to decommissioning

Introduction

This section contains information to consider when taking a product, robot or controller, out of operation.

It deals with how to handle potentially dangerous components and potentially hazardous materials.



Note

The decommissioning process shall be preceded by a risk assessment.

Disposal of materials used in the robot

All used grease/oils and dead batteries **must** be disposed of in accordance with the current legislation of the country in which the robot and the control unit are installed.

If the robot or the control unit is partially or completely disposed of, the various parts **must** be grouped together according to their nature (which is all iron together and all plastic together), and disposed of accordingly. These parts **must** also be disposed of in accordance with the current legislation of the country in which the robot and control unit are installed.

See also [Environmental information on page 38](#).

Transportation

Prepare the robot or parts before transport, this to avoid hazards.

6 Decommissioning

6.2 Environmental information

6.2 Environmental information

Introduction

ABB robots contain components in different materials. During decommissioning, all materials shall be dismantled, recycled, or reused responsibly, according to the relevant laws and industrial standards. Robots or parts that can be reused or upcycled helps to reduce the usage of natural resources.

Disposal symbol

The following symbol indicates that the product must not be disposed of as common garbage. Handle each product according to local regulations for the respective content (see table below).

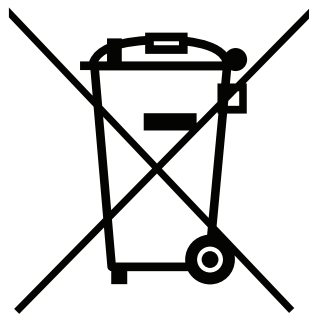

xx1800000058

Materials used in the product

The table specifies some of the materials in the product and their respective use throughout the product.

Dispose components properly according to local regulations to prevent health or environmental hazards.

Material	Example application
Steel	Cabinet structure, plates, screws, etc.

7 Reference information

7.1 Introduction

General

This chapter includes general information, complementing the more specific information in the different procedures in the manual.

7 Reference information

7.2 Unit conversion

7.2 Unit conversion

Converter table

Use the following table to convert units used in this manual.

Quantity	Units		
Length	1 m	3.28 ft.	39.37 in
Weight	1 kg	2.21 lb.	
Weight	1 g	0.035 ounces	
Pressure	1 bar	100 kPa	14.5 psi
Force	1 N	0.225 lbf	
Moment	1 Nm	0.738 lbf-ft	
Volume	1 L	0.264 US gal	

7.3 Standard toolkit for controller

General

All service (repair, maintenance and installation) instructions contain lists of tools required to perform the specified activity. All special tools, that is, all tools that are not considered as standard tools as defined below, are listed in their instructions respectively.

This way, the tools required are the sum of the standard toolkit and any tools listed in the instructions.

Standard toolkit for controller

Tool	Description
Screw driver, Torx	Tx10
Screw driver, Torx	Tx20
Screw driver, Torx	Tx25
Ball tipped screw driver, Torx	Tx25
Screw driver, flat blade	4 mm
Screw driver, flat blade	8 mm
Screw driver, flat blade	12 mm
Screw driver	Phillips-1
Box spanner	8 mm

Toolkit recommended for troubleshooting

Tool	Note
Normal shop tools	Contents as specified above.
Multimeter	-
Camera	To document problems or procedures

7 Reference information

7.4 Screw joints

7.4 Screw joints

General

This section details how to tighten the various types of screw joints on the controller. The instructions and torque values are valid for screw joints comprised of metallic materials and do *not* apply to soft or brittle materials.

Tightening torque

Before tightening any screw, note the following:

- Determine whether a standard tightening torque or special torque is to be applied. The standard torques are specified in the tables below. Any special torques are specified in the Repair, Maintenance or Installation procedure description. Any special torque specified overrides the standard value.
- Use the *correct tightening torque* for each type of screw joint.
- Only use *correctly calibrated* torque keys.
- Always *tighten the joint by hand*, and never use pneumatical tools.
- Use the *correct tightening technique*, i.e. *do not* jerk. Tighten the screw in a slow, flowing motion.
- Maximum allowed total deviation from the specified value is **10%**!

The table below specifies the recommended standard tightening torque for *oil-lubricated screws with slotted or cross-recess heads*.

Dimension	Tightening torque (Nm) Class 4.8, oil-lubricated
M2.5	0.25
M3	0.5
M4	1.2
M5	2.5
M6	5.0

7.5 Weight specifications

Definition

In all repair and maintenance instructions, weights of the components handled are sometimes specified. All components exceeding 22 kg (50 lbs) are high-lighted in this way.

To avoid injury, ABB recommends the use of lifting equipment when handling components with a weight exceeding 22 kg.

Example

Below is an example of how a weight specification is presented:



CAUTION

The transformer weighs 55 kg! All lifting equipment used must be sized accordingly!

7 Reference information

7.6 Lifting accessories and lifting instructions

7.6 Lifting accessories and lifting instructions

General

Many repair and maintenance activities require different pieces of lifting accessories, which are specified in each procedure.

The use of each piece of lifting accessories is *not* detailed in the activity procedure, but in the instruction delivered with each piece of lifting accessories.

The instructions delivered with the lifting accessories should be stored for later reference.

8 Spare parts

Spare part level

ABB spare parts are categorized into two levels, L1 and L2. Always check the part level before conducting a service work on a spare part.

- L1 spare parts

The L1 parts can be replaced in the field. The maintenance and replacement instructions given in the related product manuals must be strictly followed. If there are any problems, contact your local ABB for support.

- L2 spare parts

To replace the L2 parts require specialized training and might need special tools. Only ABB field service personnel or qualified personnel trained by ABB can replace L2 parts.

- L3 spare parts

L3 spare parts shall only be replaced or repaired by qualified ABB service technician with knowledge of the application due to reduce risk of injury or damage to equipment. Improper installation may void warranty.

Continues on next page

8 Spare parts

8.1 Controller parts

8.1 Controller parts



Note

Removed parts and spare parts must not be disassembled or opened.

Continues on next page

8.1.1 Cabinet parts

Process, fieldbus and I/O connectors

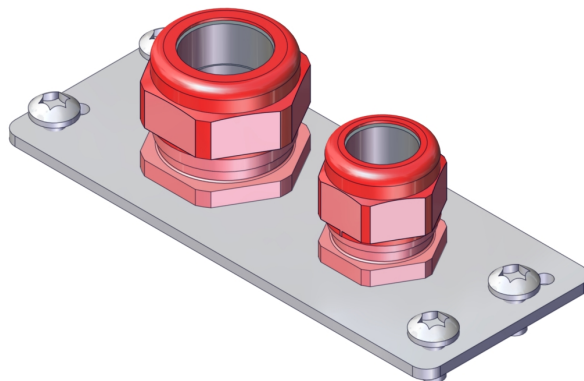

xx2400001197

	Spare part number	Description	Type	Spare part level
-	3HAC079449-001	Cable gland process interface		L1

Swing handle

	Spare part number	Description	Type	Spare part level
-	3HAC078328-001	Swinghandle with cam		L1

Cabinet wheels



xx2400000334

Spare part number	Description	Type	Spare part level
3HAC088394-001	Wheel assembly (rear)	Option 3011-1 Wheels	L1
3HAC088350-001	Castor wheel with brake (front)	Option 3011-1 Wheels	L1

Continues on next page

8 Spare parts

8.1.1 Cabinet parts

Continued

Cabinet door locks

Spare part number	Description	Type	Spare part level
3HAC074600-001	Key	Square 6 mm	L1
3HAC025309-004	Lock insert	Double bit 3	L1
3HAC025309-005	Lock insert	Slot 1, 2 x 3	L1
3HAC025309-007	Lock insert	Triangular 6,5 CNOMO	L1

8.1.2 Miscellaneous parts

Cable grommet asm

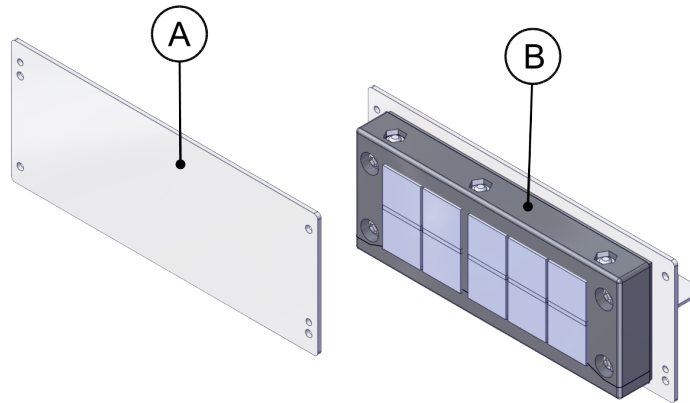

xx1900001947

	Spare part number	Description	Type	Spare part level
A	3HAC069954-001	Blind plate (baseline)		L1
B	3HAC066396-001	Cable grommet asm		L1

Dust ledge

Spare part number	Description	Type	Spare part level
3HAC088073-001	Dust ledge		L1

Door stop

Spare part number	Description	Type	Spare part level
3HAC083827-001	Door stop		L1

This page is intentionally left blank

Index

A

ambient temperature
 operation, 15
 storage, 15
assembly instructions, 17
assessment of hazards and risks, 12

B

bolt pattern, 22

C

cleaning of the controller, 26

D

dimensions, 14

E

environmental information, 38

H

hazardous material, 38
HRA, 12

I

instructions for assembly, 17
integrator responsibility, 12

L

limitation of liability, 11

N

national regulations, 12

O

operating conditions, 15
original spare parts, 11

P

protection classes, 15
protection type, 15
protective earth, 23

R

recycling, 38
regional regulations, 12
responsibility and validity, 11
robot
 protection class, 15
 protection types, 15

S

safety
 symbols on cabinet, 12
shipping, 37
steel
 disposal, 38
storage conditions, 15
system integrator requirements, 12

T

temperatures
 operation, 15
 storage, 15
tightening torque, 42
transportation, 37
transportation conditions, 15

U

upcycling, 38

V

validity and responsibility, 11

W

weight, 14



ABB AB

Robotics & Discrete Automation

S-721 68 VÄSTERÅS, Sweden

Telephone +46 10-732 50 00

ABB AS

Robotics & Discrete Automation

Nordlysvegen 7, N-4340 BRYNE, Norway

Box 265, N-4349 BRYNE, Norway

Telephone: +47 22 87 2000

ABB Engineering (Shanghai) Ltd.

Robotics & Discrete Automation

No. 4528 Kangxin Highway

PuDong New District

SHANGHAI 201319, China

Telephone: +86 21 6105 6666

ABB Inc.

Robotics & Discrete Automation

1250 Brown Road

Auburn Hills, MI 48326

USA

Telephone: +1 248 391 9000

abb.com/robotics